



**Cooking Range Line thermaline 90
Water mixing tap with lever, 1 Side
- H=250 - Marine USPHS only M2M**

ITEM # _____

MODEL # _____

NAME # _____

SIS # _____

AIA # _____



589938 (HCEABBBOOM)

Water mixing tap with lever,
one-side operated with
splashback - Marine USPHS
(only M2M)

Short Form Specification

Item No. _____

Water mixing tap with lever for hot and cold water. Unit constructed according to DIN 18860_2 with 20 mm drop nose top and 120 mm recessed plinth. Internal frame for heavy duty sturdiness in stainless steel. 3mm top with 3 mm reinforcement in 1.4301 (AISI 304). IPX6 water resistant certification. Configuration: one side operated. Can be installed on any base, also from other supplier. Bases must be designed according to the TL90 and TL85 construction guidelines.

Main Features

- Water mixing unit for hot and cold water.
- All major components may be easily accessed from the front.
- Large stainless steel tap.

Construction

- Internal frame for heavy duty sturdiness in stainless steel.
- 3mm top with 3 mm reinforcement in 1.4301 (AISI 304).
- Unit constructed according to DIN 18860_2 with 20 mm drop nose top.
- <p>Also available with 400V / 3ph / 50/60 Hz.</p>

Optional Accessories

- Portioning shelf 1000x65mm - PNC 913713
Marine USPHS (only M2M)

APPROVAL: _____



Front

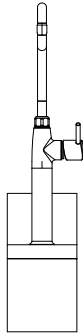

Water:

Inlet water line size:	3/4"
Incoming Cold/hot Water line size:	3/4"

Key Information:

External dimensions, Width:	200 mm
External dimensions, Depth:	900 mm
External dimensions, Height:	250 mm
Net weight:	25 kg

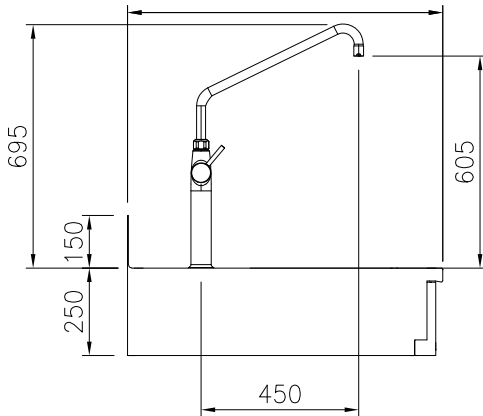
Side



CWII = Cold Water inlet 1 (cleaning)
 HWI = Hot water inlet

Top

